

Dedicated image collector

CY-505/506/507 Series

PRODUCT MANUALS

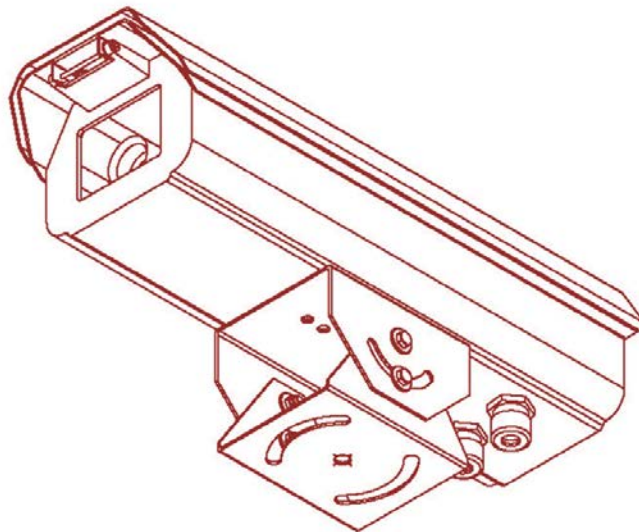

Table of Contents

Dedicated Image Collector (CY-505/506/507) Series Product Manual	1
I. Overview	1
II. Main components	1
III. Product composition, specification and package	1
1. External dimensions of collector:	1
2. Video camera assembly:	2
3. Overall connection:	2
4. Base and adapter support:	3
5. Wiring guide	3
6. Package and accessories	4
IV. Main parameters of components	4
1. Main parameters of collector protective cover:	4
2. Main parameters of video camera:	4
3. Main parameters of lens	5
4. Main parameters of switch power supply	5
V. Inspection standard	6
VI. Special statement	6



Dedicated Image Collector (CY-505/506/507)

Series Product Manual

I. Overview

CY-505/506/507 series dedicated image collector is a device specially applied to industrial and mining enterprises and large equipment CCTV monitoring systems. It is formed by integrating equipment assemblies such as LG LVC-SX811HP/LS 923P-B/LS921P –B camera, wide power input switch power supply and high-sealing-performance waterproof protective cover. The collector protective cover is internally provided with automatic temperature control device, filtering device and anti-jamming device; the camera has high resolution and sensitivity; the voltage operating range is 100-240V, the temperature operating range is -35~+50°C, and the collector can work under the environment with high relative humidity due to the fact that the IP grade of the protective cover is higher than IP67; the whole set of collector is advanced, reliable and practical and can be normally used under outdoor severe environment conditions.

II. Main components

No.	Name	Specification	Quantity	Remarks
1	Video camera	LG LVC-SX811HP LG LS 923P-B/LS 921P –B	1	CE certification
2	Lens	0380M	1	CE certification
3	Switch power supply	RS-25-12	1	CE certification
4	Line bank	AWG-29-14	1	
5	Cooling fan	RF12S625H	1	
6	Heating element	25W 8Ω	1	
7	Temperature control switch	KSD301-250V10A 8-38°C	2	
8	Outdoor protective cover	442×140×142	1	Video camera supporting IP67

III. Product composition, specification and package

1. External dimensions of collector:

The collector is attractive in appearance, as shown in Figure 1, the specification is the minimum. If a larger camera video is replaced with, the outdoor protective cover larger than the specification can be adopted.

The collector protective cover is made of high-quality aluminum alloy, sturdy, light in weight and corrosion-resistant; the surface is coated with braked varnish, thereby being rainproof, sunscreen and mist-resistant; the IP grade is high up to IP67; an intelligent dehumidifying function is further achieved, and internal steam caused by temperature difference can be removed to ensure image collection definition.

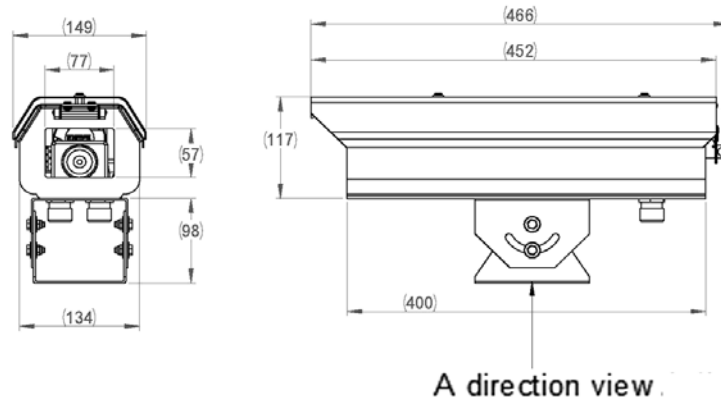

Image 1 External dimensions of collector

2. Video camera assembly:

The assembly adopts the high-definition video camera (See product parameter 2 for details) to ensure that the collected image is clear in picture quality, high in color rendition and capable of achieving low-light automatic black and white conversion and adapting to application under wharf environment.

- ◆ CY-505 is provided with LG LVC-SX811HP; CY-506 is provided with LS 923P-B; CY-507 is provided with LS921P –B.

According to Figure 2, the video camera is first installed on the insulating plate and then installed on the support plate.

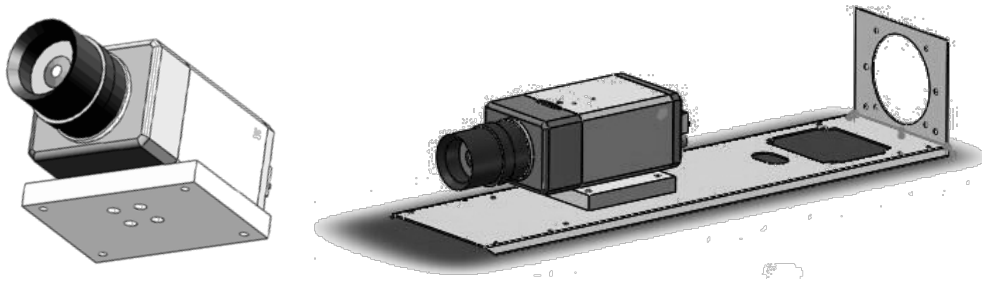

Figure 2 Video camera installation diagram

3. Overall connection:

The video camera assembly is connected with the collector protective cover and relevant components, as shown in Figure 3:

- ① Connect all cables on the video camera to the terminals according to the No.;
- ② Install the power supply, filter and anti-jamming device onto the base plate sequentially and then connect them to the terminals;
- ③ Lead the external wire harness (cables for video and power supply) into the protective cover through the outlet hole and connect it onto the corresponding terminals.

Special attention: After the overall connection, lock the packing box of the cable outlet hole to guarantee sealing performance of the collector and avoid water leakage.

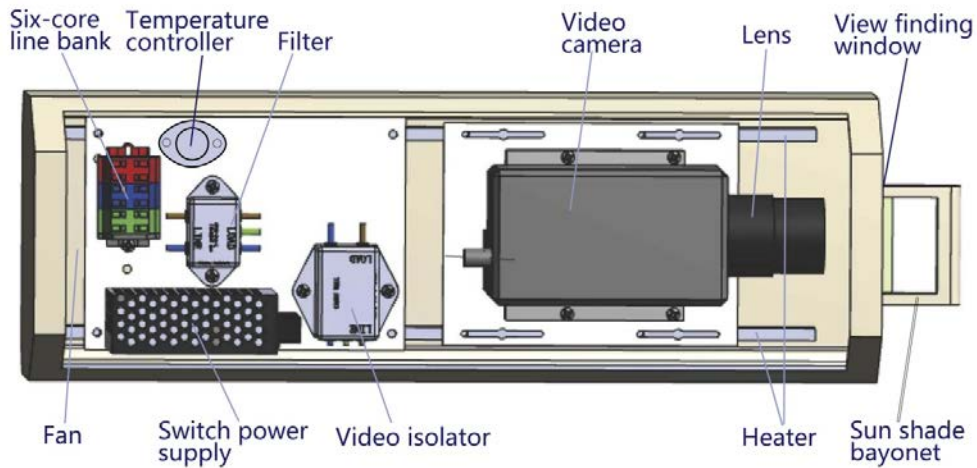

Figure 3 Collector overall installation diagram

4. Base and adapter support:

The installation dimensions of the collector protective cover base are shown as Figure 4. The attached stainless steel adapter support must be first installed on the protective cover base as per A direction view with M6 screws and spring washers (or locking washers), and then installed on corresponding device at the part requiring image collection, and the mounting hole should be drilled in the part provided with the collector as per hole dimensions in B direction view of the adapter. See Figure 5 for adapter hole position.

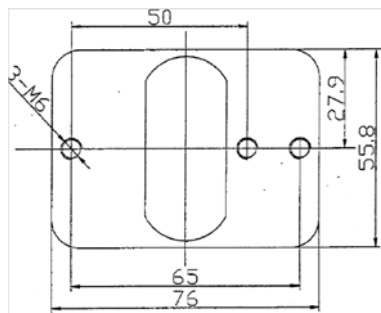

Figure 4 Protective cover base mounting dimensions

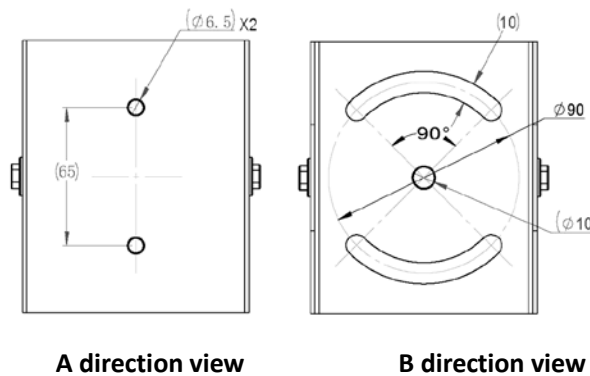

Figure 5 Adapter mounting hole dimension diagram

5. Wiring guide

The image collector must be wired as per Figure 6 Wiring guide.

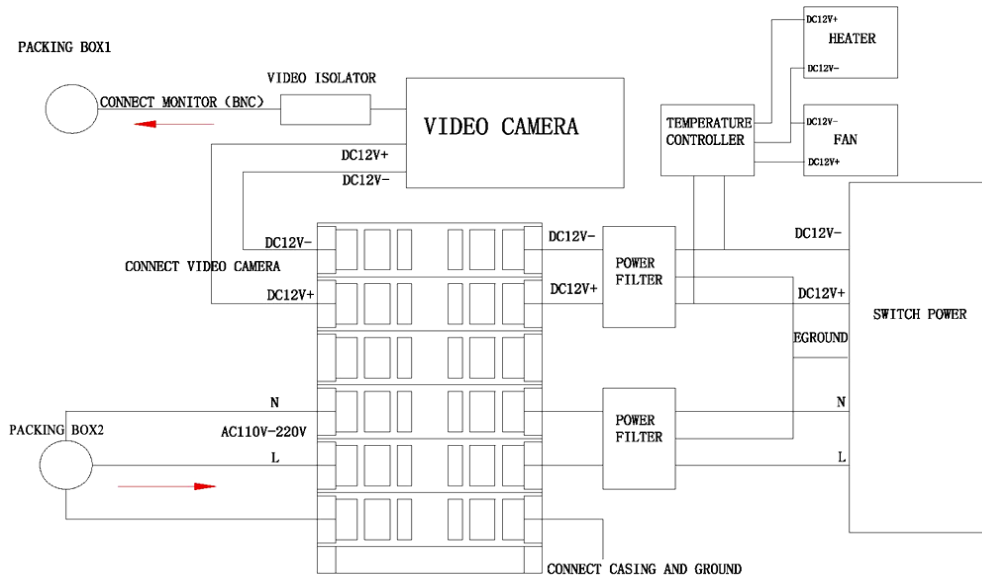

Figure 6 Wiring Guide

6. Package and accessories

The product adopts single corrugated brown paper box for package, one box for each set.

IV. Main parameters of components

1. Main parameters of collector protective cover:

Name	Parameters
Input voltage	DC12V
Power	≤20W (including air cooling heating assembly)
Fan power	≤2W
Automatic temperature control range	Heating: ON 8°C±5°C/OFF22°C±7°C, fan: ON37°C±5°C/OFF26°C±6°C
Material	Main body aluminum alloy
Weight	2.8Kg (video camera excluded)
Window diameter	∅83mm
IP grade	IP 67
Cable inlet	2 position, protective cover outer tube sealing port, maximum cable diameter 10mm
External dimensions	442mm(L)×140mm(W)×145mm(H)

2. Main parameters of video camera:

Model	LVC-SX811HP	LS923P-B	LS921P-B
Signal system	PAL		
Total pixels/Effective pixels	470K/440K		
Signal induction device	1/3" Super HAD CCD		
Lens	C/CS installation (C lens interface requires conversion)		
Diaphragm control	DC/ELC/VIDEO		
Signal processing	Digital signal processing		

Scanning process	2:1 interlacing		
Synchronizing system	Internal synchronization/External locking		
Scanning frequency	50Hz(VD)		
Resolution	Color 520TVL Black and white 530TVL	Color 620TVL Black and white 700TVL	
Signal to noise ratio	Higher than 50dB		
Standard brightness	2000Lux(3200°K)		
Minimum (F1.0)	Color 0.4Lux	Color 0.1Lux	Color 0.05Lux
Video output signal	IV p-p mixed signal		
Day & night	Automatic/Manual/External (Double-optical-filter)		
Backlight	Manual ON/OFF	Wide dynamic/Backlight compensation/Strong light inhibition	Backlight compensation/Strong light inhibition
Gain control	ON (Maximum /OFF Maximum 10dB) (with DIP switch)		
No flash	ON/OFF (with DIP switch)		
White balance	AWB/Maintain	Automatic/Manual (1,700-11,000°K)	
Exposure	Automatic DC aperture measurement/Video aperture measurement/Automatic electronic shutter (fastest 1/100000)		
Power	DC12V±10%/AC24V±10%		
Power consumption	5W(Max)	4.4W	
Operating temperature	-10°C~50°C (Humidity: 0%RH~60%)		
Storage temperature	-20°C~60°C (Humidity: 0%RH~85%)		
Approximate weight	300g	420g	
Dimensions	63×48×114.7	68×61.5×135.5	

3. Main parameters of lens

Lens model	LLS0380M
Corresponding CCD	1/3"
Interface	CS
Focal range	3.0-8mm
F value	F1.4 - C
Horizontal view angle field	96° - 70°
Minimum object dimension	0.3M

4. Main parameters of switch power supply

Model	RS-25-12
Input voltage/Current	100V-240VAC±10% 0.7A
Input frequency	50/60Hz
Output voltage/Current	DC12V±10% 2.1A
Power	25W
Short circuit protection	Troubleshoot automatic recovery
Operating ambient temperature	-10°C~50°C Relative humidity 20%~60%, RH (no condensation)
Storage ambient temperature	-20°C~85°C Relative humidity 10%~95%, RH (no condensation)

V. Inspection standard

1. Delivery inspection is sampled as per GB 2828 plan according to the delivery batch, and single sampling plan or the agreed plan in the commercial contract is adopted.
2. User acceptance should be finished within 10 work days with the written notice of the inspection result provided; otherwise, it will be deemed that all delivered products are qualified in inspection.

VI. Special statement

Dear users, please read this manual carefully before use of the collector to use it correctly

1. The product is subject to "three guarantees" (for repair replacement or compensation of faulty products) within 12 month, but abnormal damage caused by the user during installation and operation should be excluded.

2. This manual is for CY-500 series product, and complies with CE safety regulation and electromagnetic compatibility specification. Some accessories are subject to specification change without further notice.

3. As the collector is special for outdoor large equipment CCTV system image collection, the user must perform wiring and installation in strict accordance with the manual, and water leakage and fault caused by incorrect installation are out of the "three guarantees" range described in Paragraph 1, Article VI.

4. The product connection power supply is 220V; do not open the casing with the power on, or electric shock may be caused. During maintenance, only the engineering technical personnel with professional maintenance qualification can open the casing for maintenance, and should assemble the protective cover tightly as required by Paragraph 3, Article III. Pay attention to avoid damage to equipment caused by seepage due to careless protection.

5.  is the legal registered trademark of Shanghai Chengye Intelligent Technology Co., Ltd. Trademark counterfeiting is an infringement act and must assume relevant legal liabilities.

CONTACT US:

Address: Building 4, No. 318 Wuning South Road, Shanghai. 200042 China.

Tel: 86-21-52520182 62568521

Fax: 86-21-62989806-864

Website: www.cykj001.com

Let the World Rest Easy